



Symaro™

## Immersion Temperature Sensors

**QAE2164...**  
**QAE2174...**

- Active sensors for acquiring the water temperature in pipes and tanks
- Operating voltage AC 24 V or DC 13.5...35 V
- Signal output DC 0...10 V or 4...20 mA

### Use

The sensors are for use in ventilation and air conditioning plants for:

- Controlling or limiting the flow temperature
- Limiting the return temperature
- Controlling the DHW temperature

### Type summary

Type reference	Outfit	Immersion length	Operating voltage	Output signal
<b>QAE2164.010</b>	Including protection pocket with threaded nipple G ½ A	100 mm	AC 24 V ±20 % / DC 13.5...35 V	DC 0...10 V
<b>QAE2164.015</b>	Including protection pocket with threaded nipple G ½ A	150 mm	AC 24 V ±20 % / DC 13.5...35 V	DC 0...10 V
<b>QAE2174.010</b>	Including protection pocket with threaded nipple G ½ A	100 mm	DC 13.5...35 V	4...20 mA
<b>QAE2174.015</b>	Including protection pocket with threaded nipple G ½ A	150 mm	DC 13.5...35 V	4...20 mA

### Ordering

When ordering, please give name and type reference, e.g.:

Immersion temperature sensor **QAE2164.010**

## Equipment combinations

All systems or devices that are capable of acquiring and handling the sensor's DC 0...10 V or 4...20 mA output signal.

## Function

The immersion temperature sensor acquires the temperature of the medium via its sensing element whose resistance value changes as a function of the temperature. This change is converted to a DC 0...10 V or 4...20 mA output signal, depending on the type of sensor. The output signal corresponds to the selected temperature range.

## Mechanical design

The immersion temperature sensor consists of housing, printed circuit board, connection terminals, immersion rod and protection pocket. The 2-sectional housing is comprised of base and removable cover (snap-on design). The measuring circuit and the setting element are located on the printed circuit board inside the cover, the connection terminals on the base.

Cable entry is made via the M16 cable entry gland (IP54) supplied with the sensor which can be screwed into the housing. Immersion rod and housing are rigidly connected. The rod sits inside the protection pocket.

Setting element

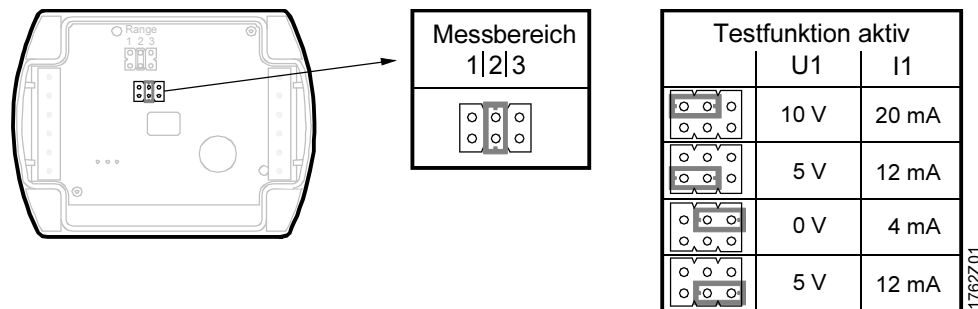

The setting element is located inside the cover. It consists of 6 pins and a shorting plug. It is used to select the required measuring range and to activate the test function.

The different plug positions have the following meaning

- *For the temperature measuring range:*
  - Shorting plug in the left position (R1) = 0...100 °C,
  - Shorting plug in the mid position (R2) = -10...+120 °C (factory setting),
  - Shorting plug in the right position (R3) = 0...70 °C
- *For activating the test function:*
  - Shorting plug in the horizontal position: The values according to the table "Test function active" will be made available at the signal output.

Fault

In the event of fault, the output signal will reach 0 V (4 mA) after 60 seconds.

## Accessories (not included with standard delivery)

Name	Material	Nominal pressure	Type of sealing	Immersion length	Type reference
Protection pocket	V4A (1.4571)	PN16	Threaded with sealing means	100 mm	<b>ALT-SS100</b>
Protection pocket	V4A (1.4571)	PN16	Threaded with sealing means	150 mm	<b>ALT-SS150</b>
Protection pocket	V4A (1.4571)	PN40	With flange for flat seal	100 mm	<b>ALT-SSF100</b>
Protection pocket	V4A (1.4571)	PN40	With flange for flat seal	150 mm	<b>ALT-SSF150</b>

For other protection pocket accessories, refer to Data Sheet N1194.

If the nominal pressure exceeds PN10, protection pockets made of stainless steel (V4A) are required. The temperature measuring range must be selected on the sensor, if required.

**Mounting and installation notes**

Depending on use, the sensor should be located as follows:

- For flow temperature control (heating flow):
  - Directly after the pump if the pump is located in the flow
  - 1.5 to 2 m after the mixing valve if the pump is located in the return
- For return temperature limitation:

In the return at a location where the temperature can be correctly acquired  
 The sensor should be installed in an elbow such that the immersion rod or the protection pocket faces the direction of flow. The water must be well mixed where the temperature is acquired. This is downstream from the pump or, if the pump is mounted in the return, at least 1.5 m after the mixing point.

The sensor should be mounted such that the cable does not enter from the top.

With all types of sensors, the immersion length must be a minimum of 60 mm!

The sensor must not be covered by lagging.

To fit the sensor, a threaded fitting or T-piece G ½ must be welded into the pipe.

Mounting

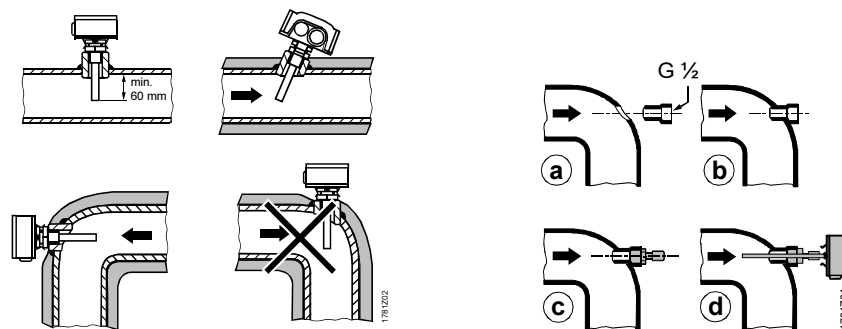

Note!

For sensors with non-sealing threaded nipples G ½, sealing means must be used with the threaded connection (e.g. hemp, Teflon tape or similar).

Mounting Instructions are printed on the packaging.

**Technical data**

Power supply	Operating voltage	refer to "Type summary"
	Frequency	50/60 Hz at AC 24 V
	Power consumption	≤1 VA
Line lengths for measuring signal	Perm. cable lengths	
	Copper cable 0.6 mm dia.	50 m
	Copper cable 1 mm <sup>2</sup>	150 m
	Copper cable 1.5 mm <sup>2</sup>	300 m
Functional data	Measuring ranges	-10...+120 °C (R2 = factory setting), 0...100 °C (R1), 0...70 °C (R3)
	Immersion length	refer to "Type summary"
	Sensing element	Pt 1000
	Time constant	
	With pocket	30 s at 2 m/s
	Without pocket	8 s at 2 m/s
	Measuring accuracy	refer to adjacent diagram
	Output signal, linear (terminal U1)	DC 0...10 V ≙ -10...+120 °C (factory setting) or 0...100 °C or 0...70 °C, max. ±1 mA
	Output signal, linear (terminal I1)	4...20 mA ≙ -10...+120 °C (factory setting) or -35...+35 °C or 0...70 °C
	Nominal pressure	PN 10

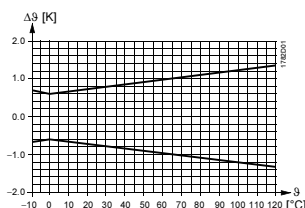

Protective data	Housing	IP 54 to IEC 529
	Safety class	III to EN 60 730
Electrical connections	Connection terminals for	1 x 2.5 mm <sup>2</sup> or 2 x 1.5 mm <sup>2</sup>
	Cable entry gland (enclosed))	M 16 x 1.5
Environmental conditions	Operation	IEC 721-3-3
	Climatic conditions	class 3K5
	Temperature (housing)	-40...+70 °C
	Humidity (housing)	5...95 % r. h.
Materials and colors	Transport	IEC 721-3-2
	Climatic conditions	class 2K3
	Temperature	-25...+70 °C
	Humidity	< 95 % r. h.
Standards	Mechanical conditions	class 2M2
	Base	polycarbonate, RAL 7001 (silver-grey)
	Cover	polycarbonate, RAL 7035 (light-grey)
	Immersion rod	stainless steel to DIN 17 440 steel 1.4571
	Protection pocket	brass (CuZn37)
	Cable entry gland	PA, RAL 7035 (light-grey)
	Packaging	corrugated cardboard
Weight	Product safety	
	Automatic electrical controls for household and similar use	EN 60 730-1
	Electromagnetic compatibility	
	Immunity	EN 61 000-6-2
Emissions	EN 61 000-6-3	
CE-conformity to	EMC Directive 89/336/EEC	
E-conformity to		
Australian EMC Framework	Radio Communication Act 1992	
Radio Interference Emission Standard	AS/NZS 3548	
Weight	Incl. packaging	
	QAE2164.010	approx. 0.22 kg
	QAE2164.015	approx. 0.24 kg
	QAE2174.010	approx. 0.22 kg
	QAE2174.015	approx. 0.24 kg

## Connection terminals

QAE2164...		<p>G, G0    Operating voltage AC 24 V (SELV) or DC 13.5...35 V</p> <p>U1        Signal output DC 0...10 V for measuring range -10...+120 °C (factory setting), 0...100 °C or 0...70 °C</p>
QAE2174...		<p>G1        Operating voltage DC 13.5...35 V</p> <p>I1        Signal output 4...20 mA for measuring range -10...+120 °C (factory setting), 0...100 °C or 0...70 °C</p>

## Dimensions (in mm)

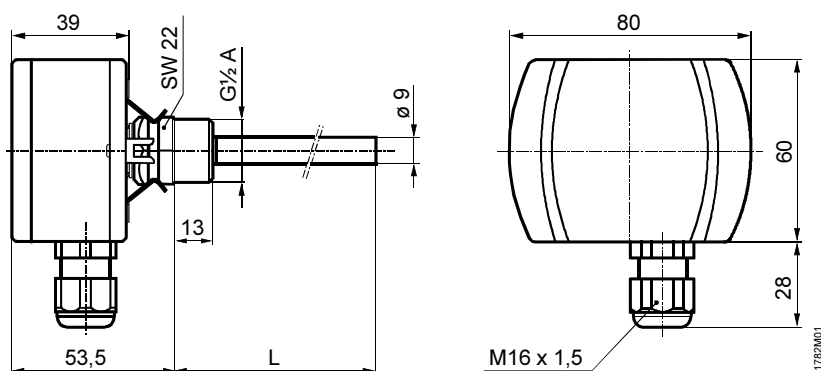

Type	L
QAE2164.010	100
QAE2164.015	150
QAE2174.010	100
QAE2174.015	150